

Plan View

10'

10'

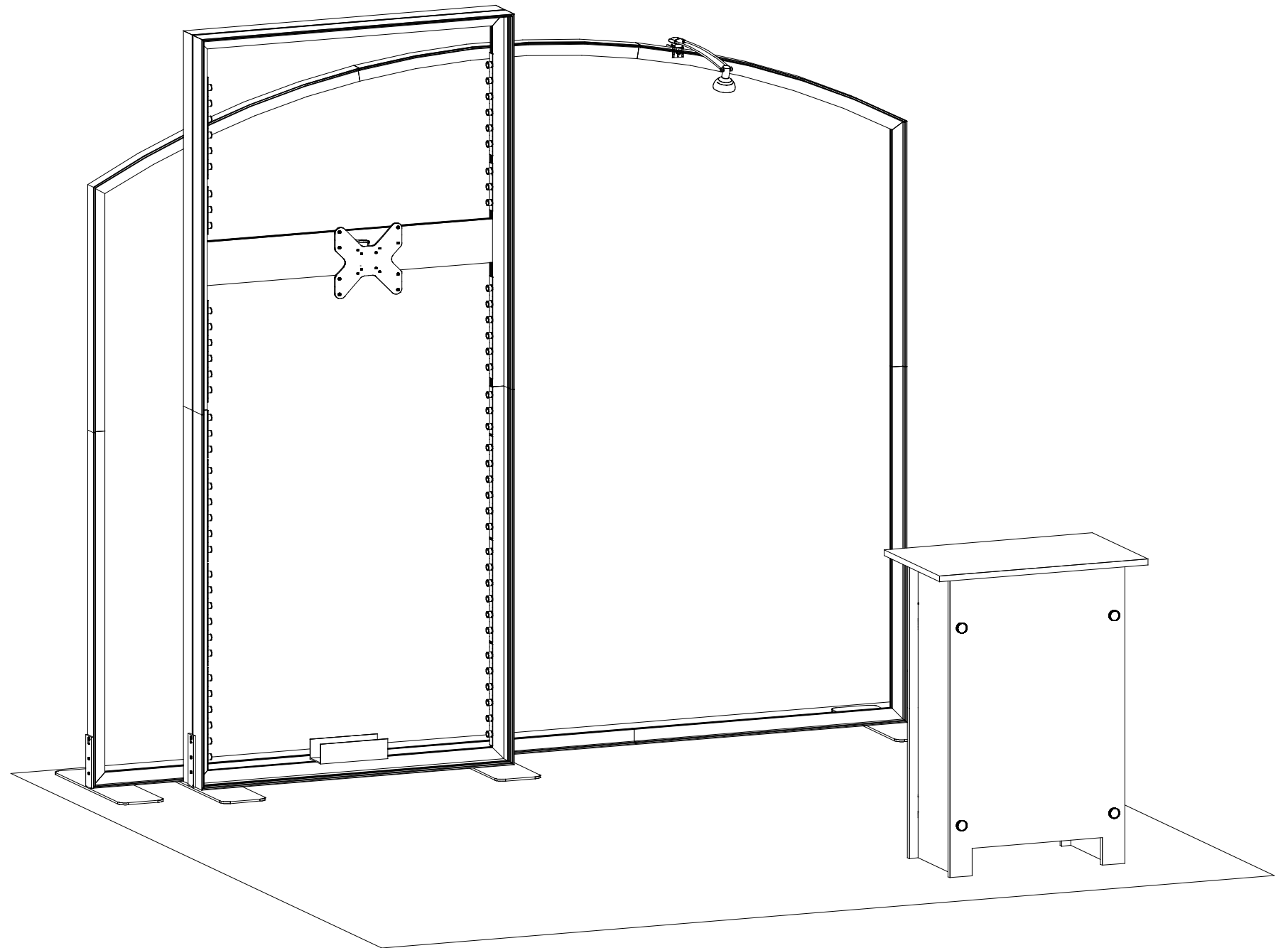

SETUP INSTRUCTIONS

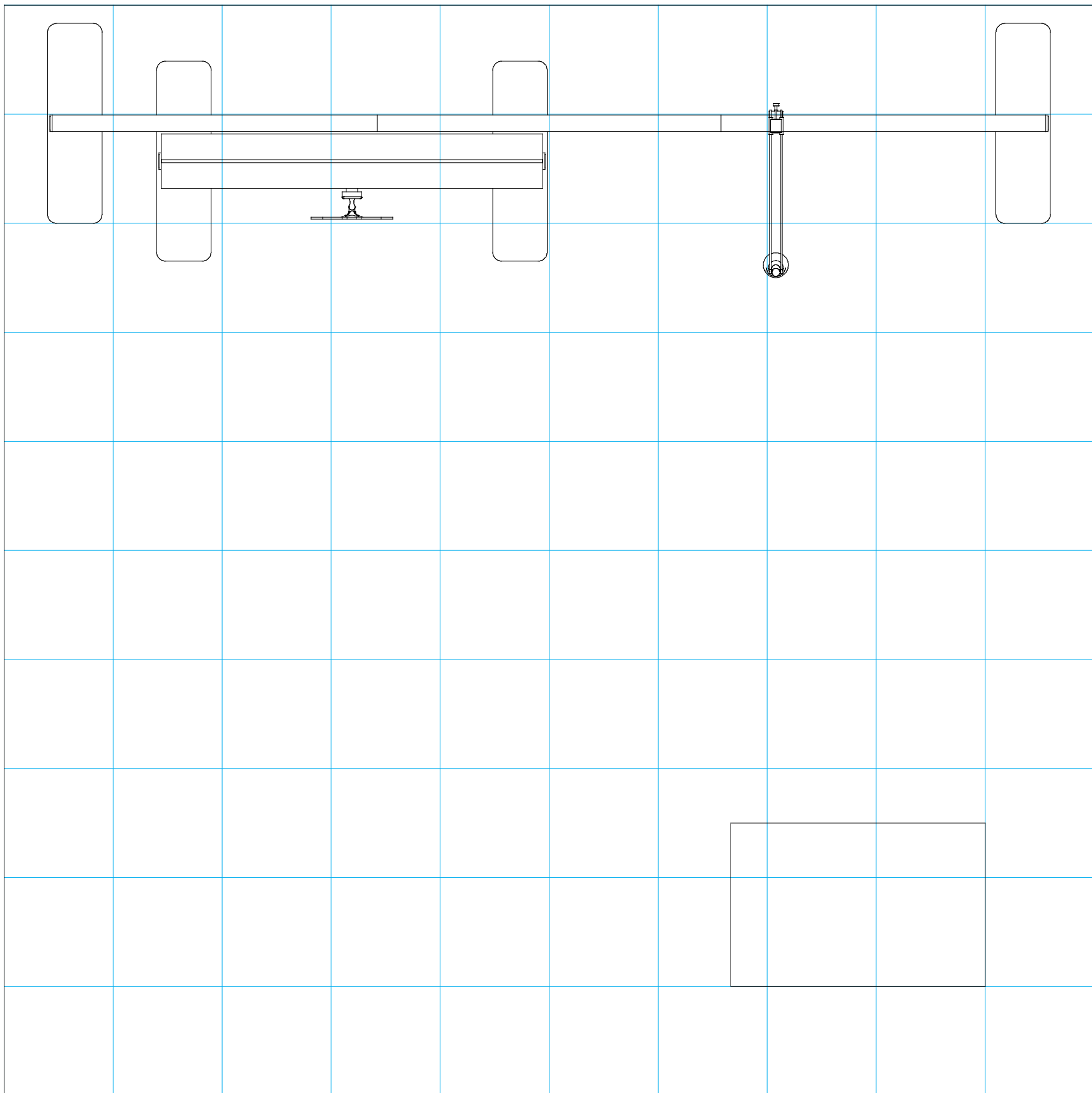

= 1 sq foot

General Setup Instructions

- Read entire setup instruction manual prior to unpacking parts and pieces.
- The setup instructions are created specifically for this configuration.
- Setup instructions are laid out sequentially in steps, including exploded views with detailed explanation for assembly.

Cleaning & Packing

- For Cleaning Metal, Plex, & Laminate Parts: Use a **MILD NON-ABRASIVE** cleanser and soft cloth/paper towel to clean all surfaces.
- Keep exhibit components away from heat and prolonged sun exposure.
Heat and UV exposure will warp and fade components.
- Retain all provided Packing Materials. All provided packing materials are for ease of repacking & component protection.

Disassembly

- For loss prevention, tighten all set screws and locks during disassembly.

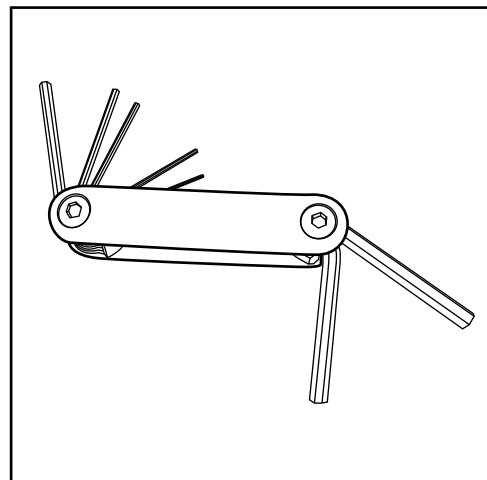

Hex Tool - Essential for Assembly

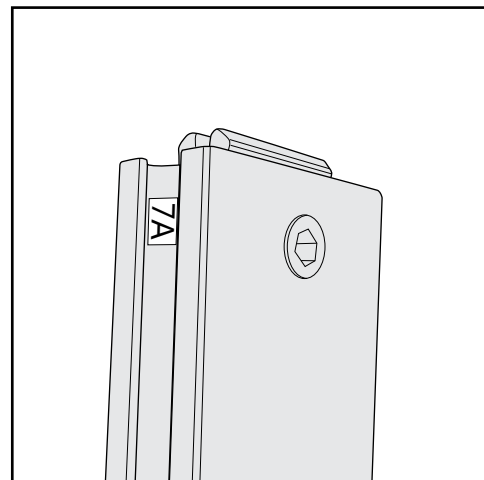

Part Identification - Numbering

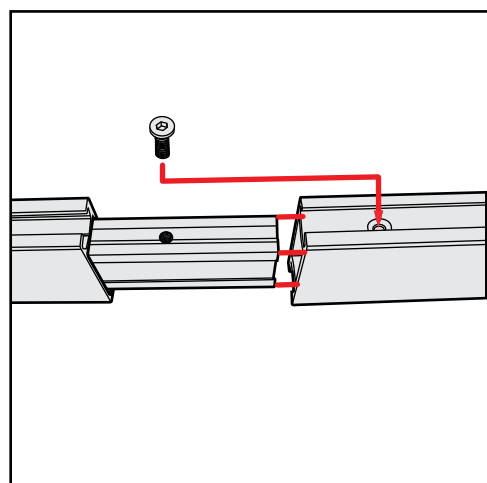

Spline Connection

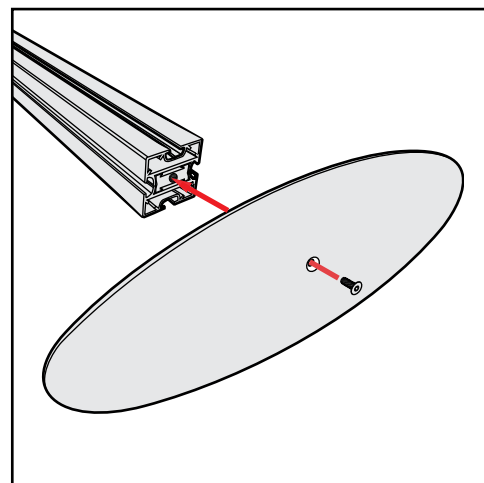

Base Plate & Extrusion Connection

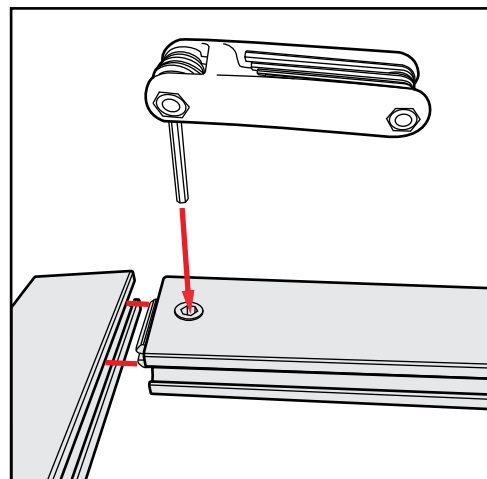

Extrusion & Lock Connection

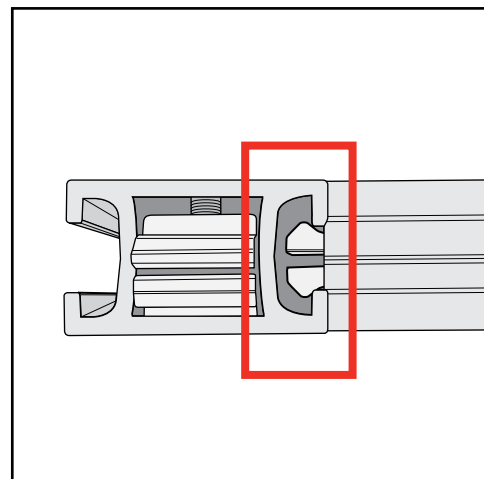

Engaged Lock



WARNING

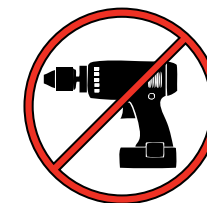

DO NOT USE POWER TOOLS



LADDERS OR LIFTS
MAY BE REQUIRED



ALL CONNECTIONS MUST
BE TIGHTLY SECURED

Straight Connection

When assembling frame, first attach all **straight connectors**, then attach **corner connectors**.

- 1) Place extrusions end-to-end.
- 2) Loosen all knobs, then slide **straight connector** across the seam of extrusions.
- 3) Tighten all knobs to secure connection.

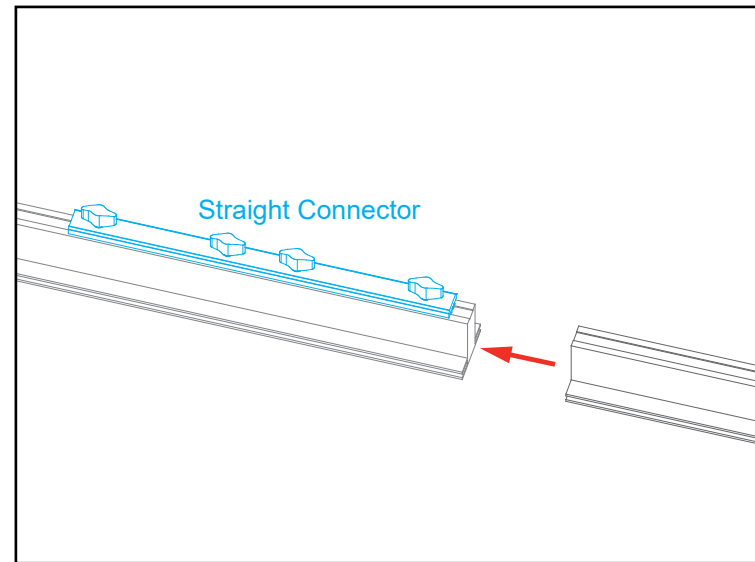

Slide connector across seam of extrusions.
Tighten all knobs.

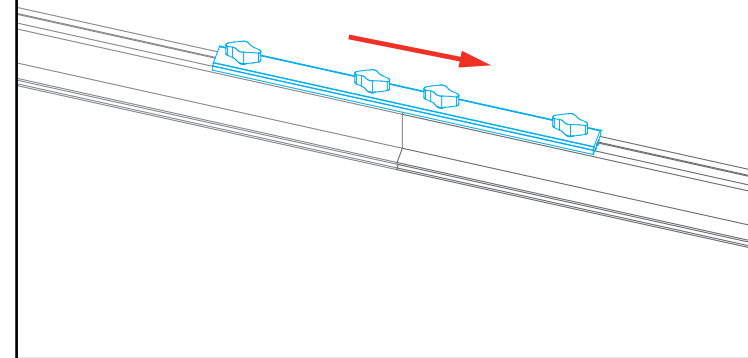

Disassembly

- 1) Loosen all knobs.
- 2) Slide connectors off of one extrusion.
- 3) Tighten knobs to prevent loss during packing & shipping.

Keep straight connectors in groove of extrusion. Do not remove connectors during disassembly.

All knobs must be tightened securely to ensure a proper connection.

Corner Connection

- 1) Loosen knobs, then slide vertical extrusions onto **corner connectors** of **lower** horizontal extrusion.
- 2) Slide **corner connectors** of **upper** horizontal extrusion into grooves of vertical extrusions.
- 3) Tighten all knobs to secure connection.

Disassembly

- 1) Loosen knobs on vertical extrusions.
- 2) Slide the vertical extrusions off of **corner connectors** on lower and upper horizontal extrusions.

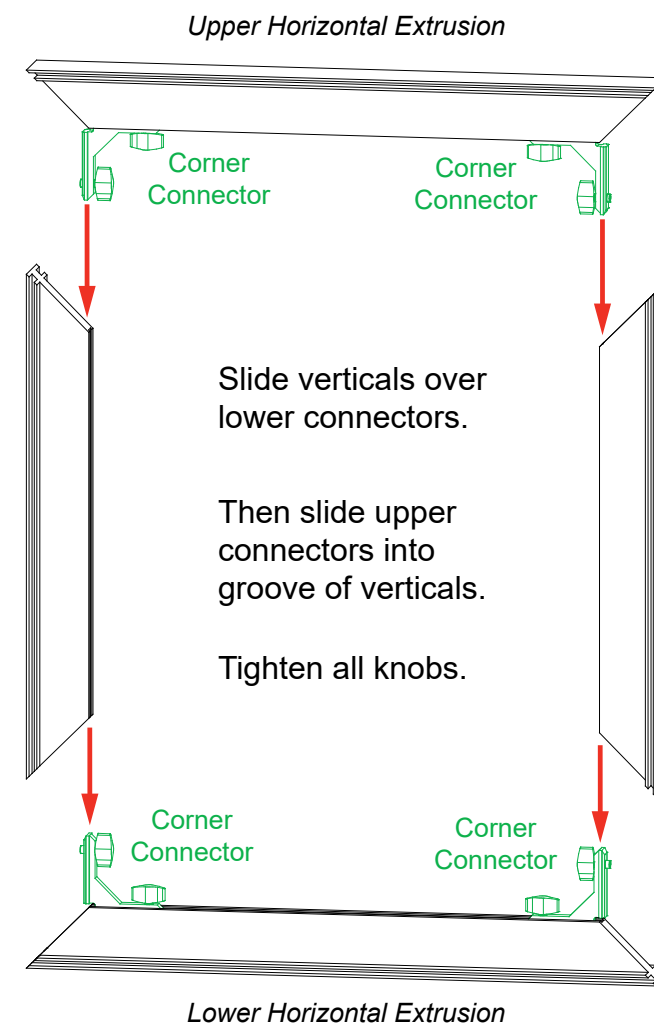

Slide verticals over lower connectors.

Then slide upper connectors into groove of verticals.

Tighten all knobs.



Adjust connectors if necessary to prevent gaps in connection.

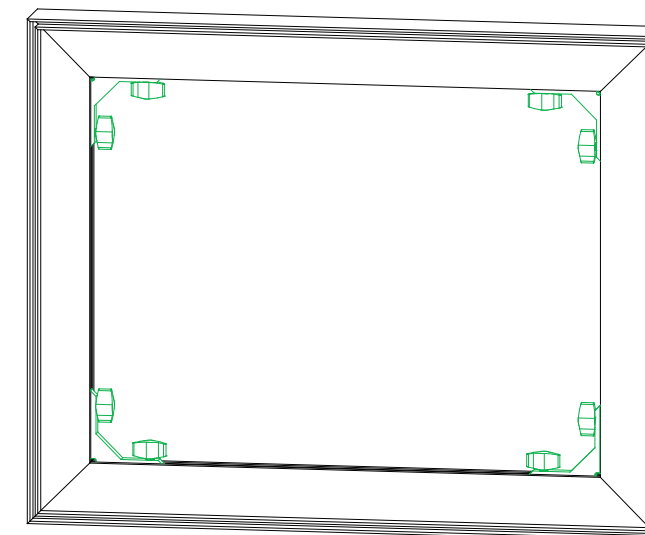

COMPLETED ASSEMBLY

All knobs must be tightened securely to ensure a proper connection.

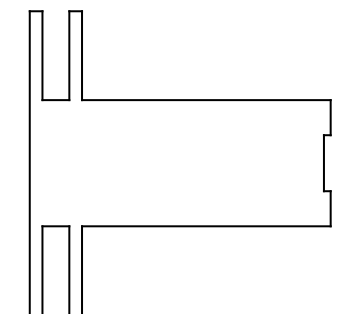

TSP49 Profile

Straight Connection

When assembling frame, first attach all **straight connectors**, then attach **corner connectors**.

- 1) Place extrusions end-to-end.
- 2) Loosen all knobs, then slide **straight connectors** across the seam of extrusions.
- 3) Tighten all knobs to secure connection.

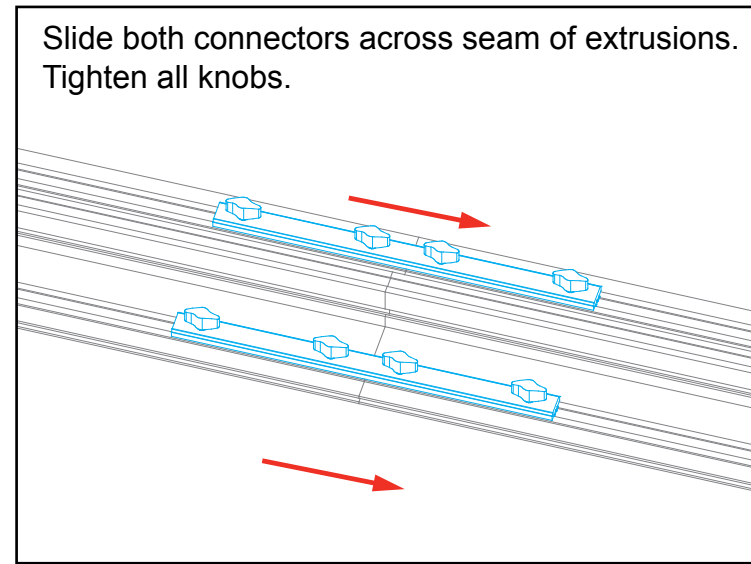
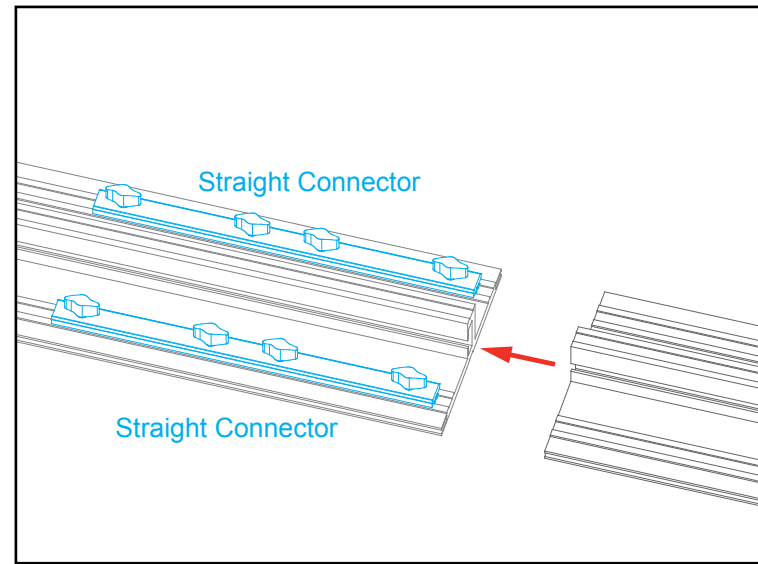

All knobs must be tightened securely to ensure a proper connection.

Disassembly

- 1) Loosen all knobs.
- 2) Slide connectors off of one extrusion.
- 3) Tighten knobs to prevent loss during packing & shipping.

Keep straight connectors in groove of extrusion. Do not remove connectors during disassembly.

Corner Connection

- 1) Loosen knobs, then slide vertical extrusions onto **corner connectors** of **lower** horizontal extrusion.
- 2) Slide **corner connectors** of **upper** horizontal extrusion into grooves of vertical extrusions.
- 3) Tighten all knobs to secure connection.

Disassembly

- 1) Loosen knobs on vertical extrusions.
- 2) Slide the vertical extrusions off of **corner connectors** on lower and upper horizontal extrusions.

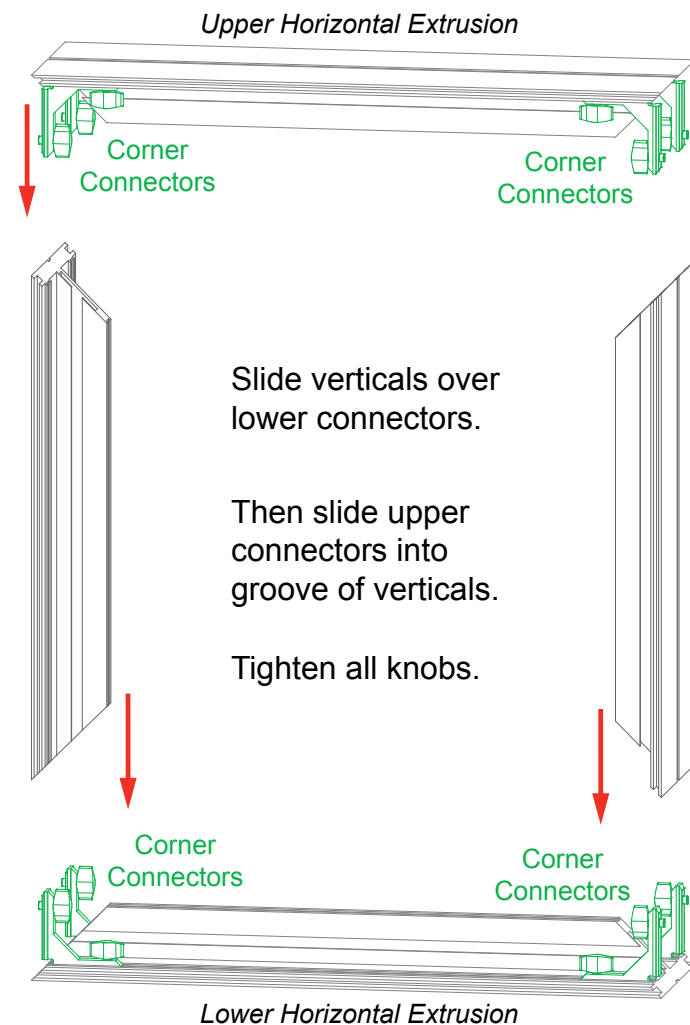

Adjust connectors if necessary to prevent gaps in connection.

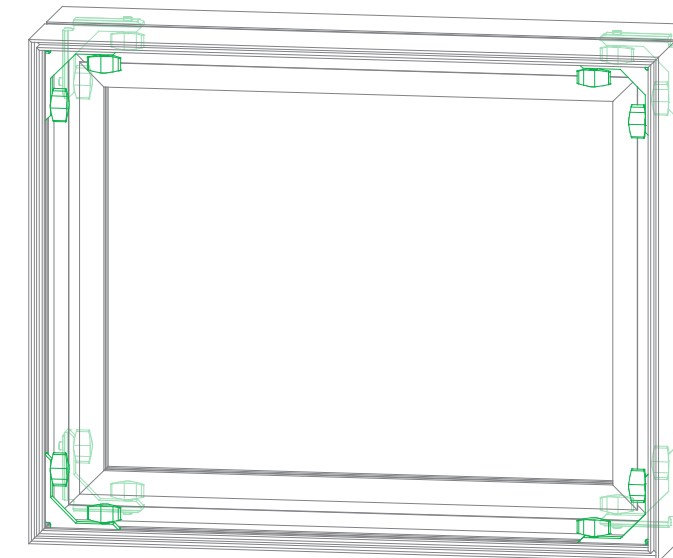

COMPLETED ASSEMBLY

All knobs must be tightened securely to ensure a proper connection.

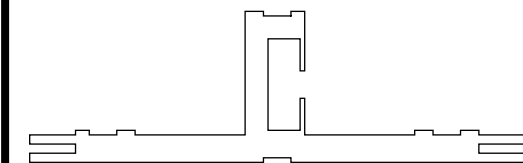

CEI152 Profile

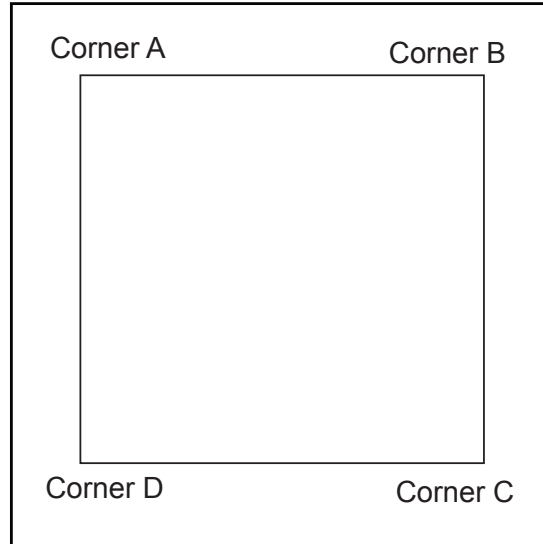

It is important to first insert graphic into each alternate corner then to the sides of the frame. If this is not done, graphic will not fit into the frame correctly.

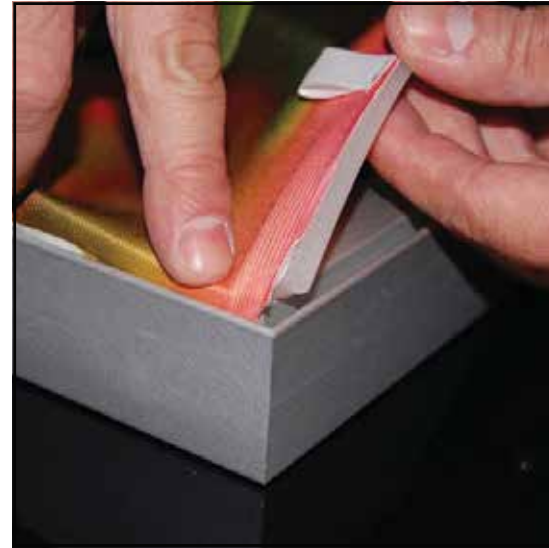

Step 1
Insert corner A. Turn edge of graphic so silicon welt is perpendicular to face of graphic. Insert narrow side of welt with fabric to outside into the channel. Repeat for other side of this corner.



Step 2
Repeat Step 1 for opposite corner C, then insert corner B, followed by corner D, to complete the installation of the corners.



Step 3
Once all corners are inserted, press one silicon edge into channel from corners and work toward the center. Make sure welt is fully inserted into channel. Continue until all sides are done. Smooth out edges of graphic.

Graphic Removal

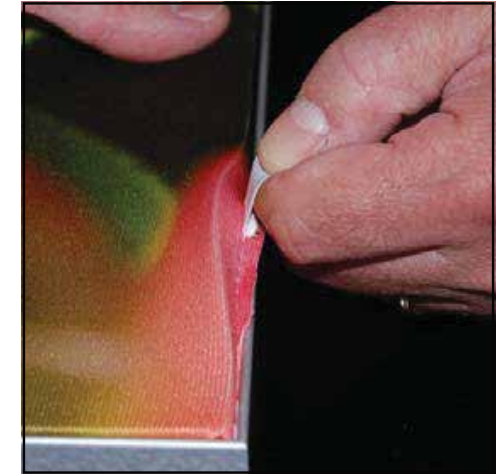

To remove the graphic from the frame, locate the fabric pull tab. Gently pull up on the tab to remove the fabric.

Top View of Each Level

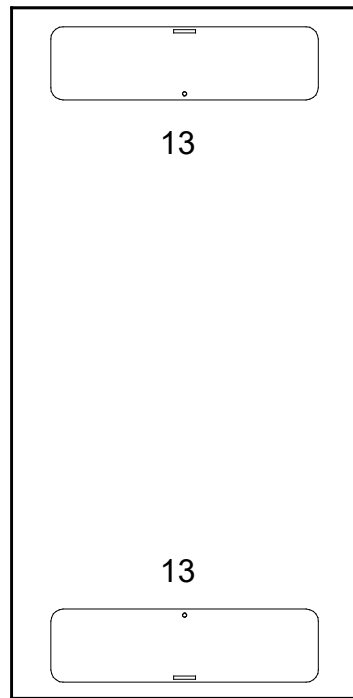

Level 1
(Bottom level)

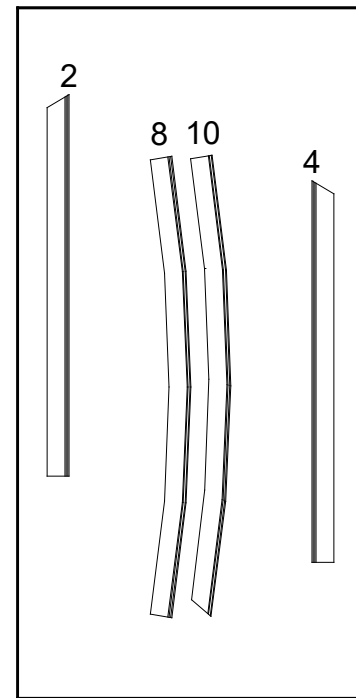

Level 2

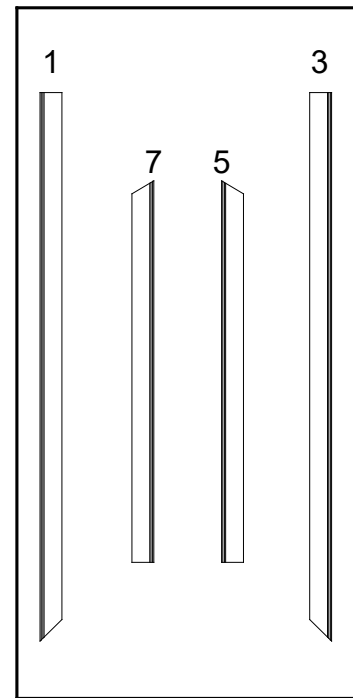

Level 3

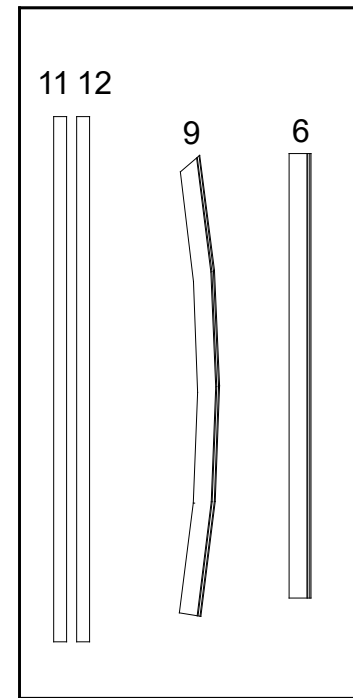

Level 4

Lights
Setup Hardware

Graphics

Top View of Each Level

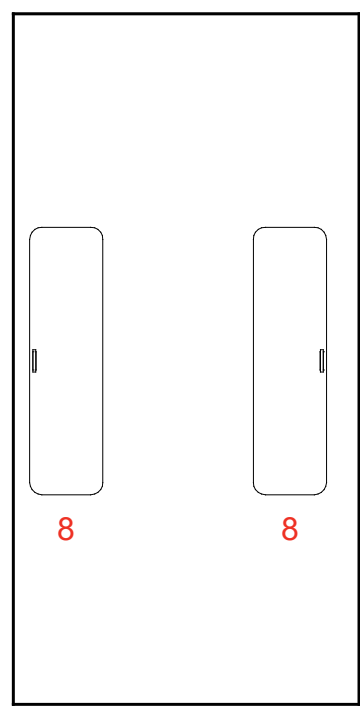

Level 1
(Bottom level)

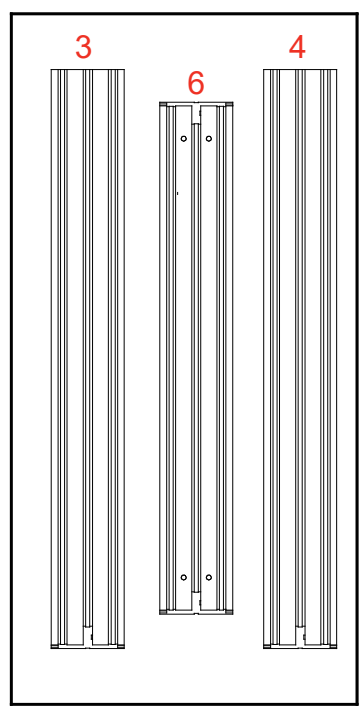

Level 2

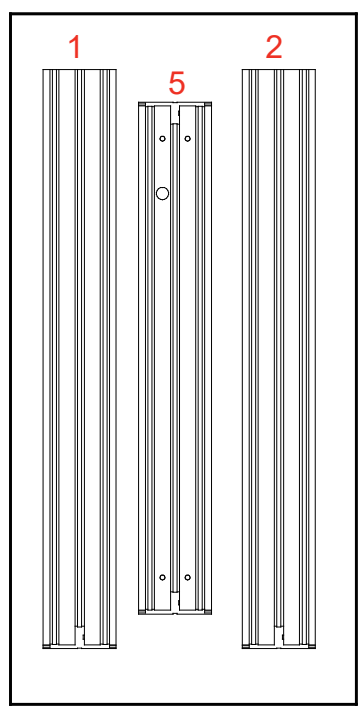

Level 3

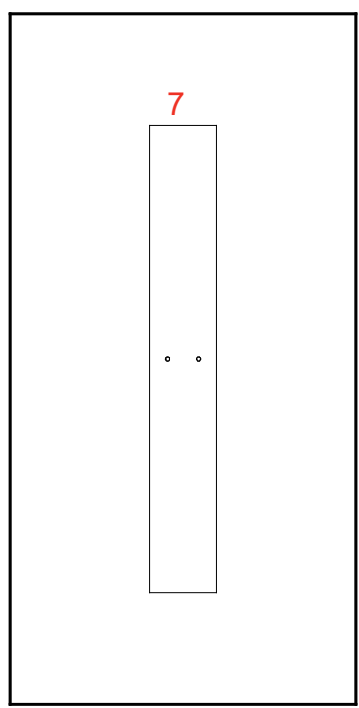

Level 4

Graphics

Setup Hardware
Monitor Mount

Top View of Each Level

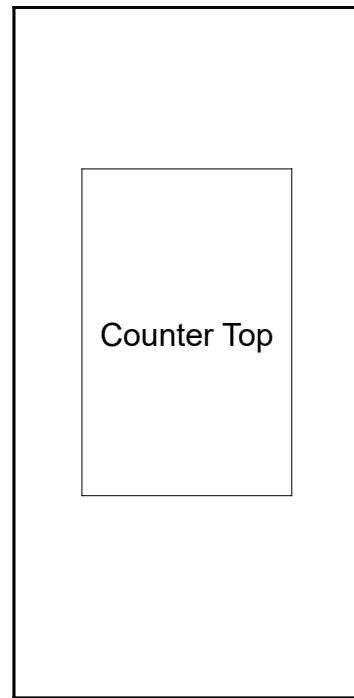

Level 1
(Bottom level)

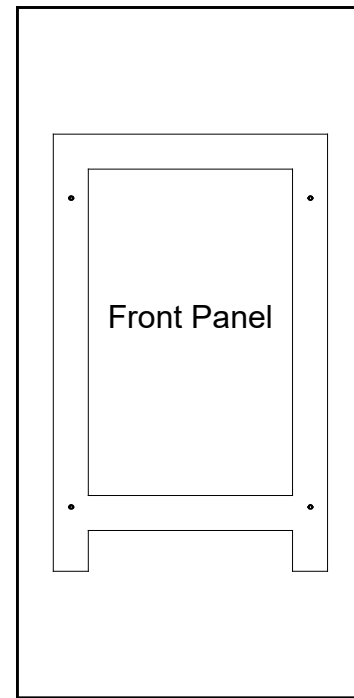

Level 2

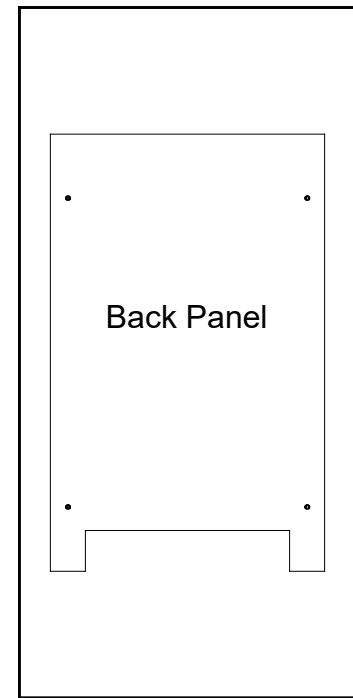

Level 3

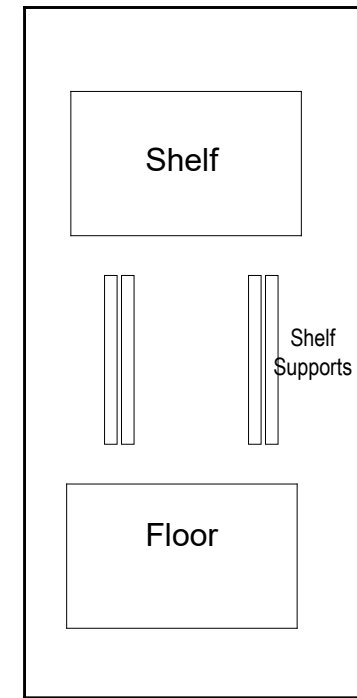

Level 4

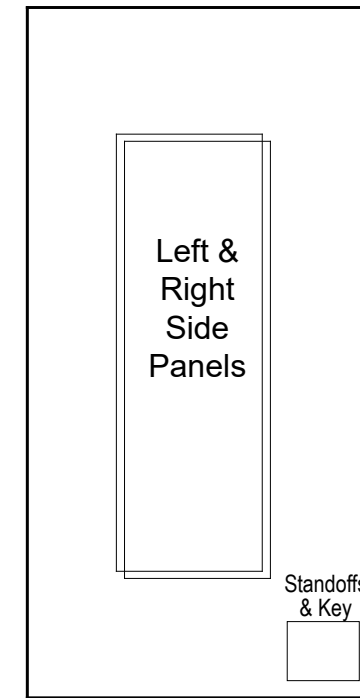

Level 5

| Item | Qty. | Description |
|------|------|--|
| 1 | 1 | 45"h TSP49 Vertical Extrusion |
| 2 | 1 | 31.305"h TSP49 Vertical Extrusion |
| 3 | 1 | 45"h TSP49 Vertical Extrusion |
| 4 | 1 | 31.305"h TSP49 Vertical Extrusion |
| 5 | 1 | 36.467"w TSP49 Horizontal Extrusion |
| 6 | 1 | 36.467"w TSP49 Horizontal Extrusion |
| 7 | 1 | 36.467"w TSP49 Horizontal Extrusion |
| 8 | 1 | 38.019"w TSP49 curved Horizontal Extrusion |
| 9 | 1 | 38.019"w TSP49 curved Horizontal Extrusion |
| 10 | 1 | 38.019"w TSP49 curved Horizontal Extrusion |
| 11 | 1 | 45.209"h Z45 Vertical Extrusion |
| 12 | 1 | 41.209"h Z45 Vertical Extrusion |
| 13 | 2 | 6" x 22" End Base Plate w/ foot |

Steps:

Refer to the TSP49 Frame Assembly general information page.

- 1) Assemble vertical extrusions [1-2], [3-4], [11-12] & horizontals [5-6-7], [8-9-10] together, using **Tool-less Spline connectors** labeled [X] & [Y].
- 2) Connect vertical assemblies [1/2], [3/4] between horizontal assemblies [5/6/7], [8/9/10], using **Tool-less Corner Connectors** labeled [A] & [B].
- 3) Install Base Plates [13] to bottom corners of frame assembly as shown. See **Base Plate Attachment** detail.
- 4) Lift frame to upright position, then connect vertical assembly [11/12] between horizontal assemblies [5/6/7], [8/9/10] using **Connection Lock w/ Knob**.

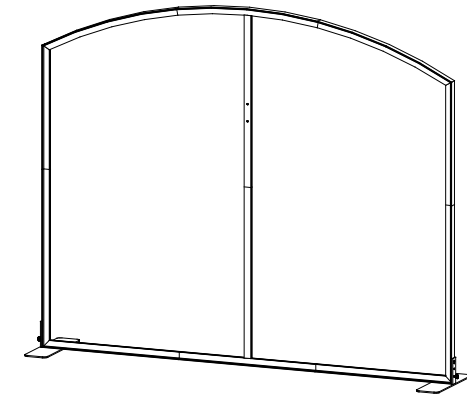

When assembled

Assemble frame flat on ground.

*** Tool-less Spline Connector**

1. Place extrusions end-to-end.
2. Slide tool-less connectors across seam of extrusions.
3. Tighten all knobs to secure connection.

*** Tool-less Corner Connector**

1. Slide extrusion onto Corner Connector.
2. Tighten all knobs to secure connection.

Keep corner connectors attached to horizontal extrusions.

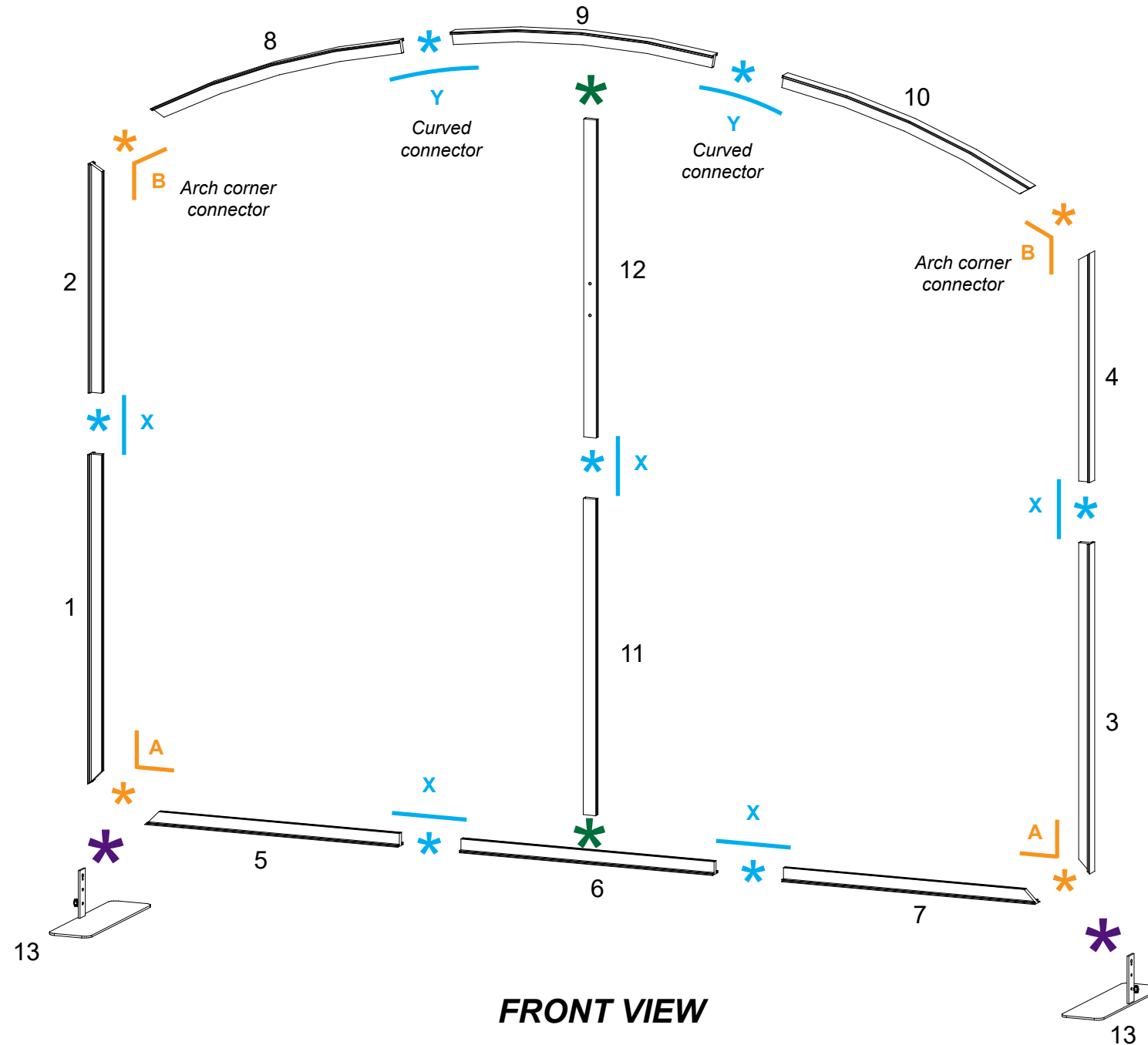

*** Connection Lock w/ Knob**

*Knobs face **back** of assembly.*

BACK VIEW

*** Base Plate Attachment**

- 1) Place key hole over bolt on panel & slide down.
- 2) Twist knob to secure connection.

SEG Graphic Installation

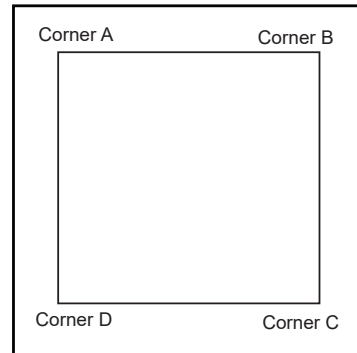

It is important to first insert graphic into each alternate corner, then to the sides of the frame. If this is not done, graphic will not fit into the frame correctly.

Step 1
Insert corner A. Turn edge of graphic so silicon welt is perpendicular to face of graphic. Insert narrow side of welt with fabric to outside into the channel. Repeat for other side of this corner.



Step 2
Repeat Step 1 for opposite corner C, then insert corner B, followed by corner D, to complete the installation of the corners.



Step 3
Once all corners are inserted, press one silicon edge into channel from corners and work toward the center. Make sure welt is fully inserted into channel. Continue until all sides are done. Smooth out edges of graphic.

Graphic Removal

To remove the graphic from the frame, locate the fabric pull tab. Gently pull up on the tab to remove the fabric.

- Steps:
- 1) Apply SEG Graphic to front of assembled frame.
 - 2) Attach Light to top of backwall as shown.
See [Light Attachment](#) detail.

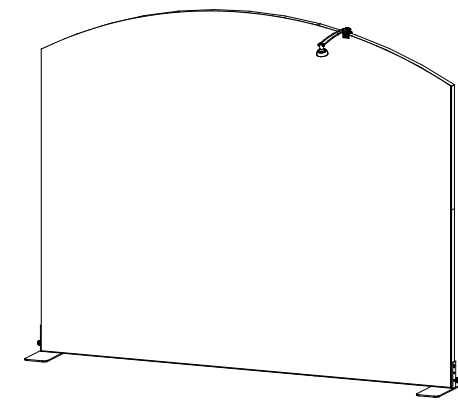

When assembled

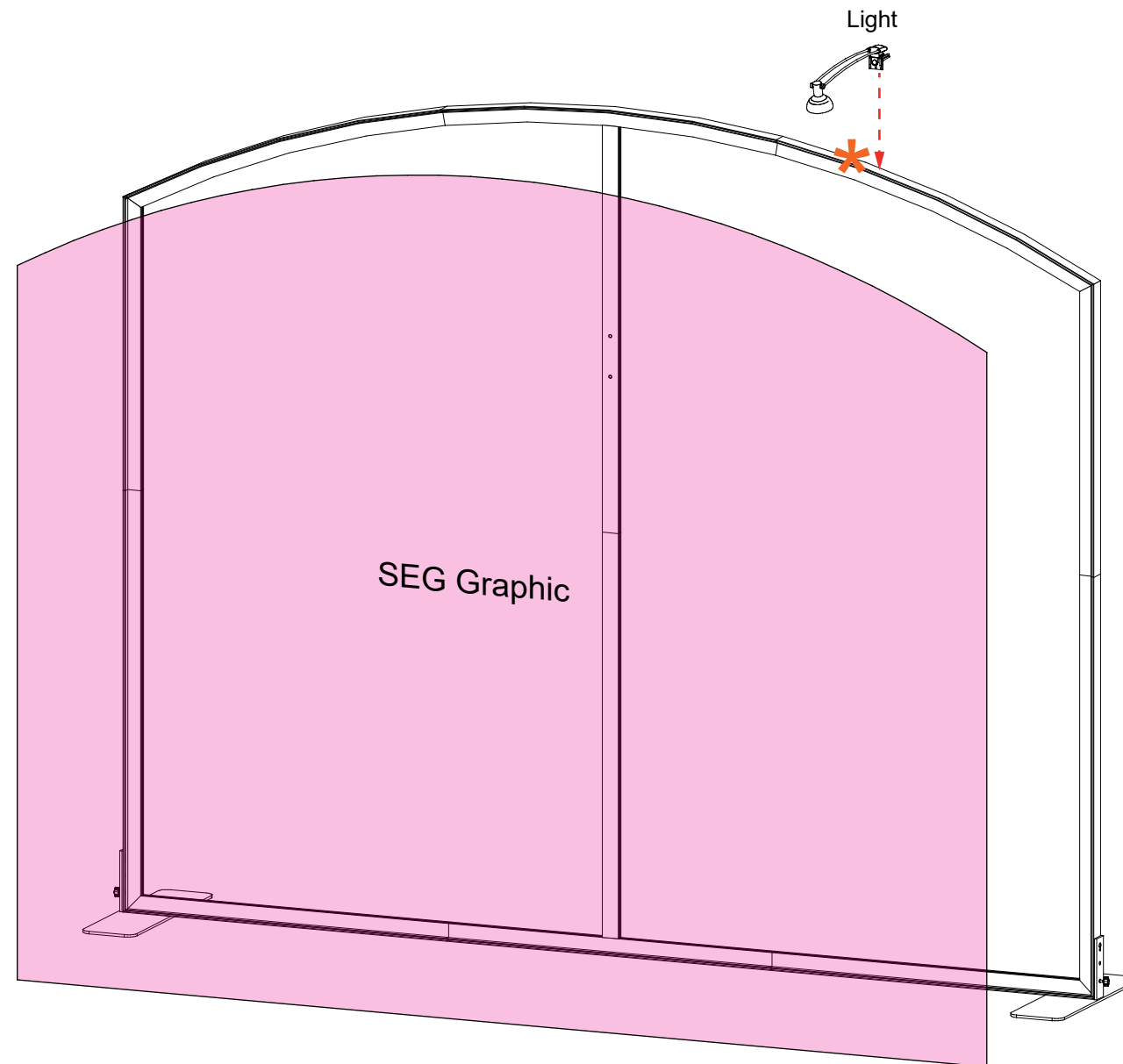

FRONT VIEW

*** Light Attachment**

Attach clamp of stem light to top of horizontal extrusion where desired.

Twist knob on back to tighten in place.

BACK VIEW

| Item | Qty. | Description |
|------|------|------------------------------------|
| 1 | 1 | 47.5”h CEI152 Vertical Extrusion |
| 2 | 1 | 47.5”h CEI152 Vertical Extrusion |
| 3 | 1 | 47.5”h CEI152 Vertical Extrusion |
| 4 | 1 | 47.5”h CEI152 Vertical Extrusion |
| 5 | 1 | 42”w CEI152 Horizontal Extrusion |
| 6 | 1 | 42”w CEI152 Horizontal Extrusion |
| 7 | 1 | 38.353”w Z140 Horizontal Extrusion |
| 8 | 2 | 6” x 22” End Base Plate w/ foot |
| -- | 1 | U-Channel |

Steps:

Refer to the CEI152 Frame Assembly general information page.

- 1) Attach U-Channel to horizontal [5]. See [U-Channel Attachment](#) detail.
- 2) Assemble vertical extrusions [1-2], [3-4] together, using Tool-less Spline connectors.
- 3) Connect vertical assemblies [1/2], [3/4] between horizontals [5,6] using Tool-less Corner Connectors.
- 4) Attach horizontal [7] between verticals as shown.
- 5) Install Base Plates [8] to bottom corners of frame assembly as shown. See [Base Plate Attachment](#) detail.
- 6) Connect power cords to Supernova lights as shown.

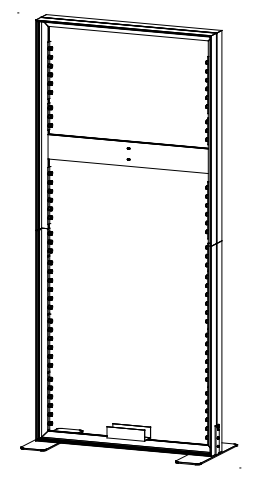

When assembled

Assemble frame flat on ground.

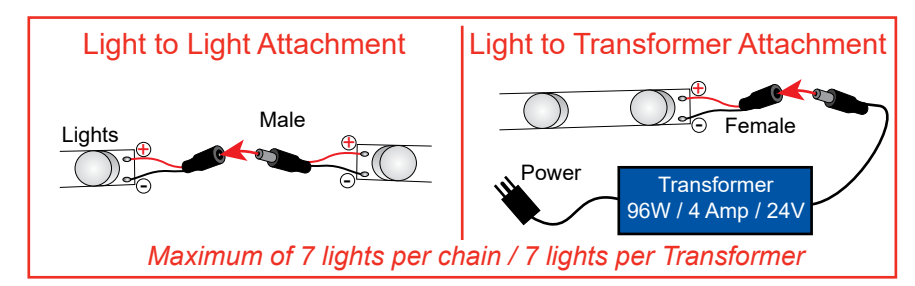
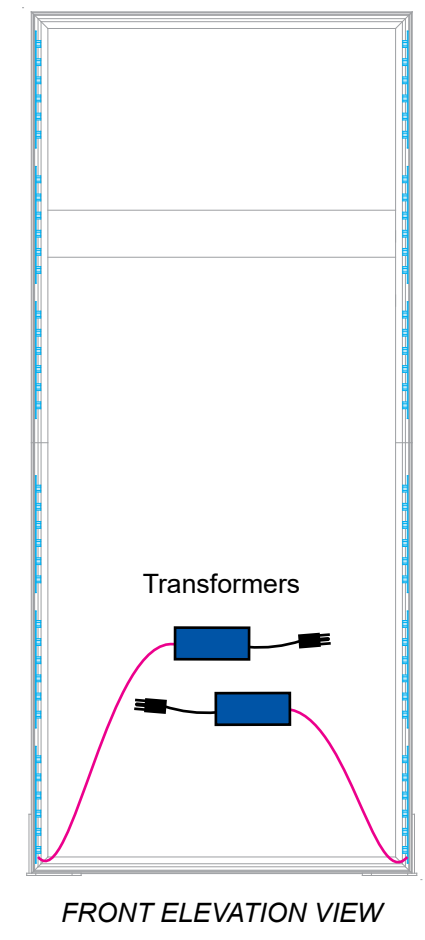
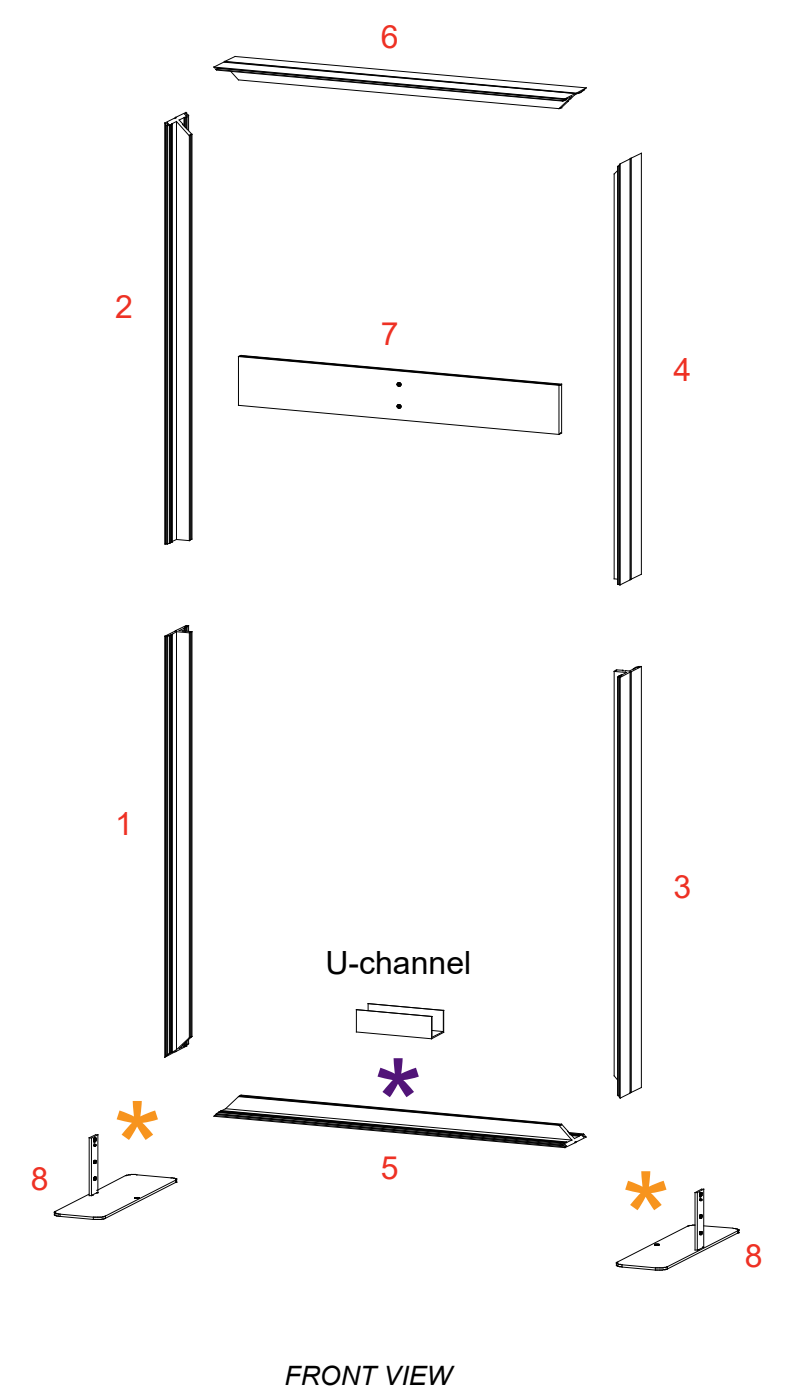
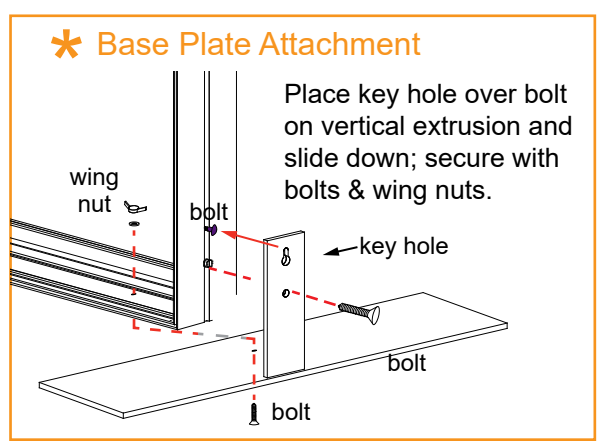
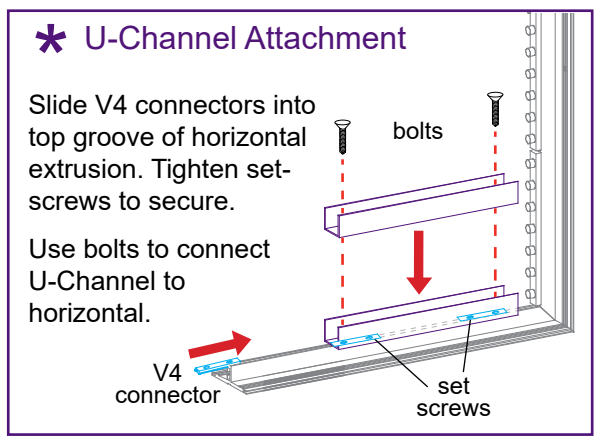

*** Monitor Mount Attachment**

Attach Monitor Mount to horizontal extrusion using standoff barrels, bolts & wing nuts.

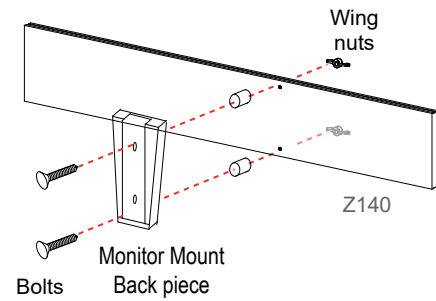
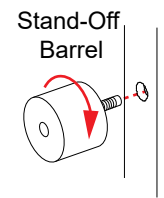

Slide monitor mount into back piece.

Steps:

- 1) Apply SEG graphic to *front* of frame assembly.
- 2) Connect Monitor Mount to horizontal [7].
See **Monitor Mount Attachment** detail.
- 3) Apply SEG graphic to *back* of frame assembly.

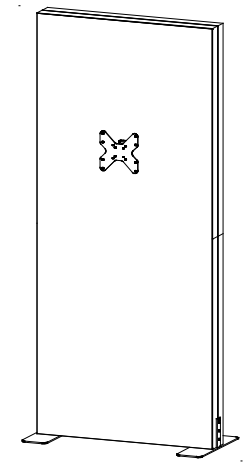

When assembled

SEG Graphic Installation

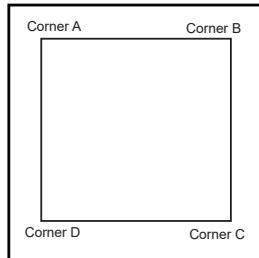

It is important to first insert graphic into each alternate corner, then to the sides of the frame. If this is not done, graphic will not fit into the frame correctly.



Step 1
Insert corner A. Turn edge of graphic so silicon welt is perpendicular to face of graphic. Insert narrow side of welt with fabric to outside into the channel. Repeat for other side of this corner.



Step 2
Repeat Step 1 for opposite corner C, then insert corner B, followed by corner D, to complete the installation of the corners.



Step 3
Once all corners are inserted, press one silicon edge into channel from corners and work toward the center. Make sure welt is fully inserted into channel. Continue until all sides are done. Smooth out edges of graphic.

Graphic Removal



To remove the graphic from the frame, locate the fabric pull tab. Gently pull up on the tab to remove the fabric.

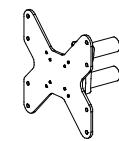

Monitor Mount

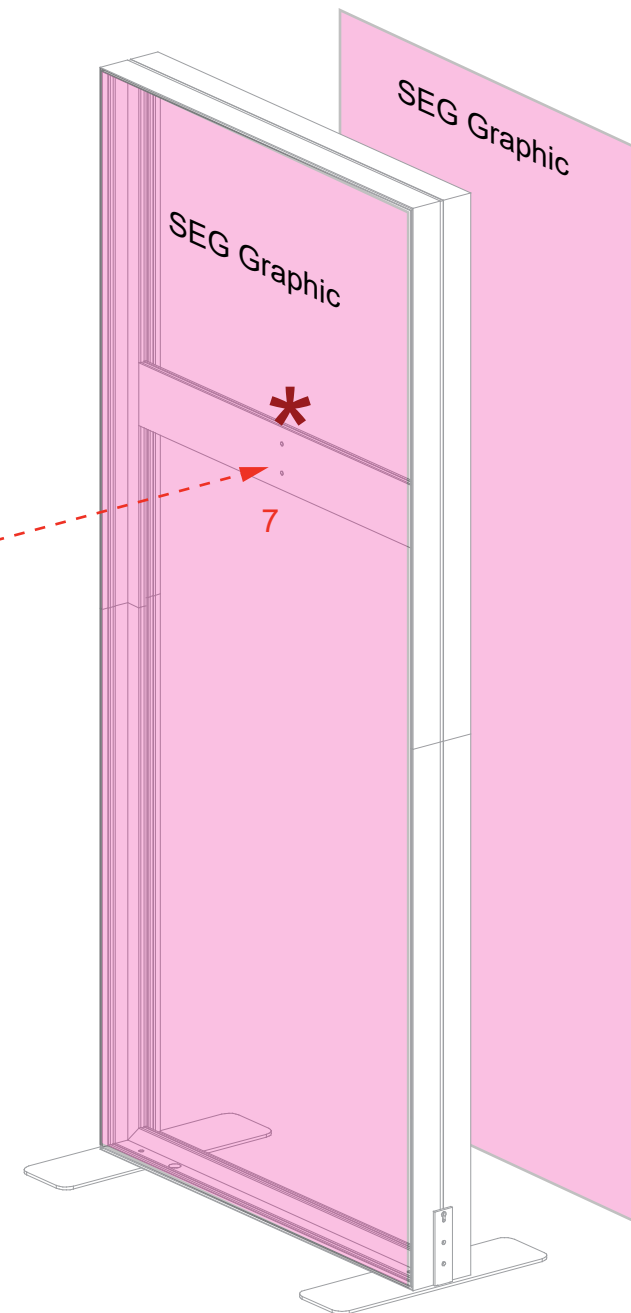

Steps:

- 1) Attach pins at bottom interior of side panels. *Note: Pins are designed to be slightly angled.*
- 2) Use screw caps to secure side panels to front & back panels.
- 3) Slide floor into the bottom of assembled pedestal base. The floor will sit on pins of the side panels.
- 4) Connect **shelf supports** with Velcro inside of panels, then place shelf on top of supports.
- 5) Attach Counter Top to assembled pedestal base. See **Counter Top Attachment** detail.

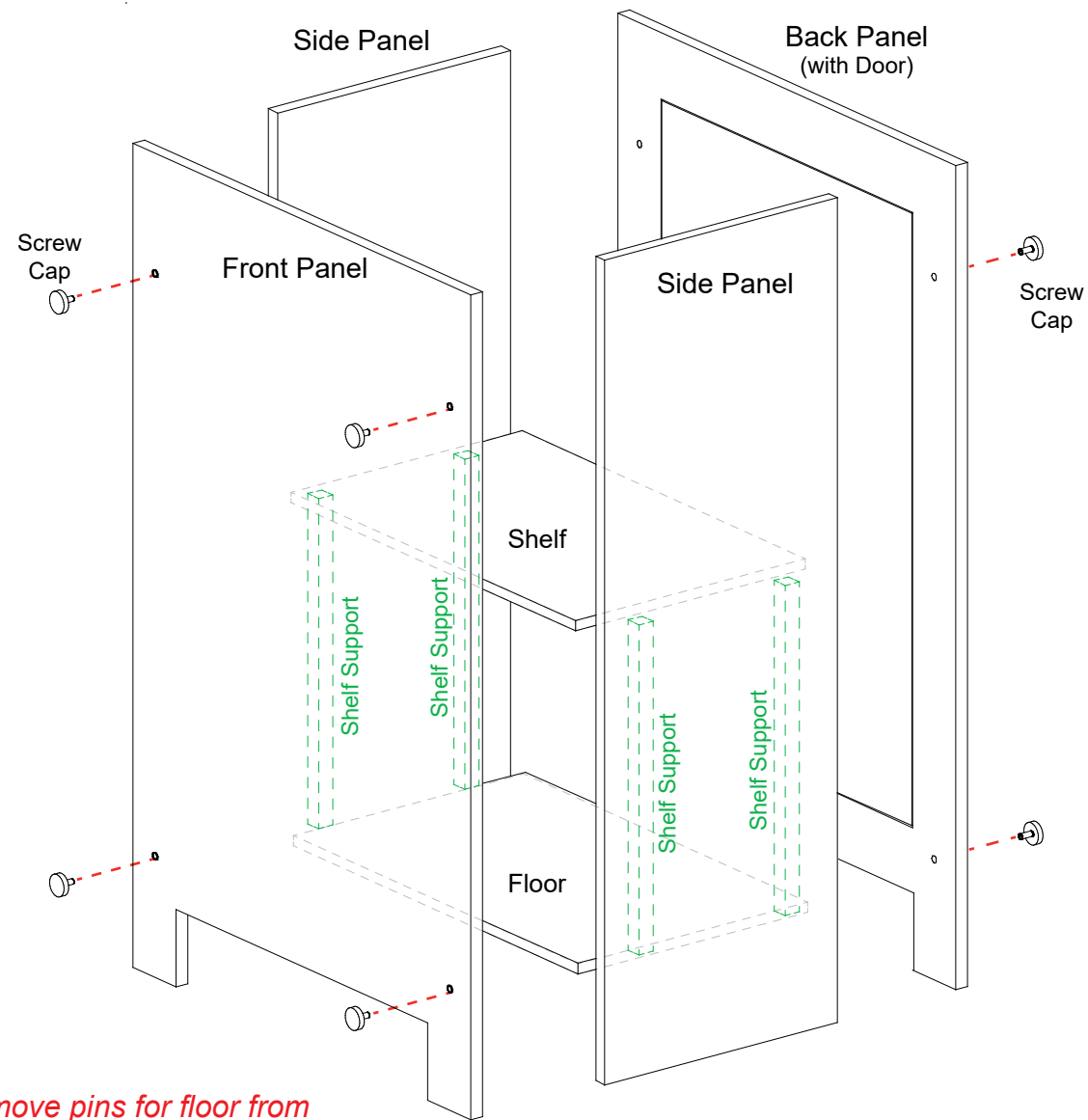

Pedestal Base Assembly

NOTE: Remove pins for floor from side panels when packing.

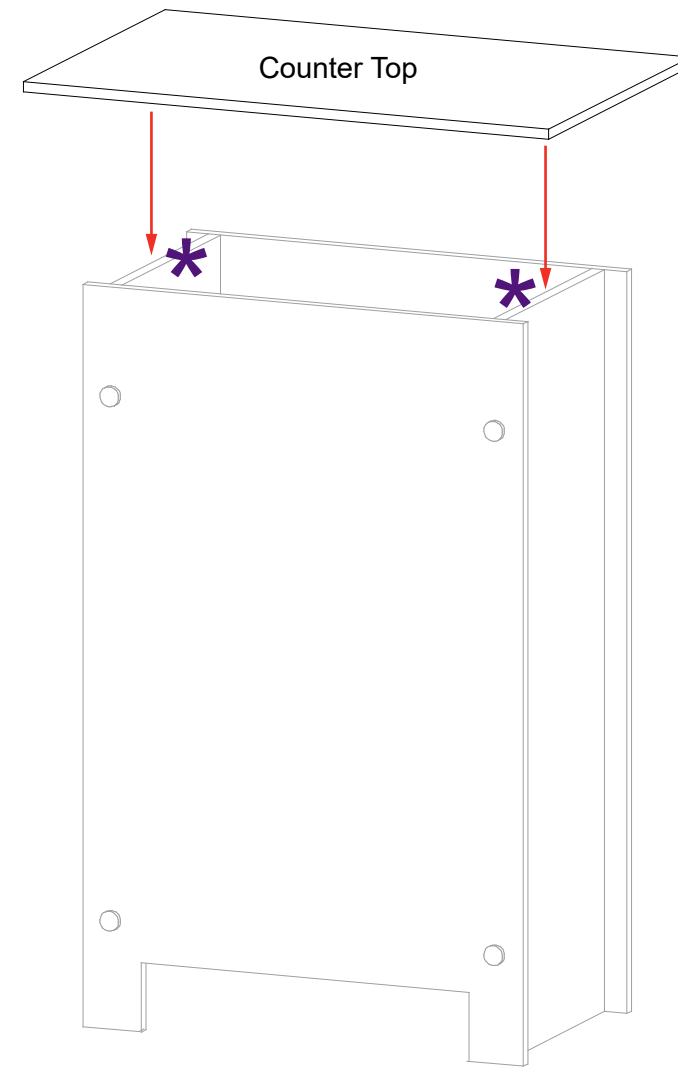

Pedestal Top Attachment

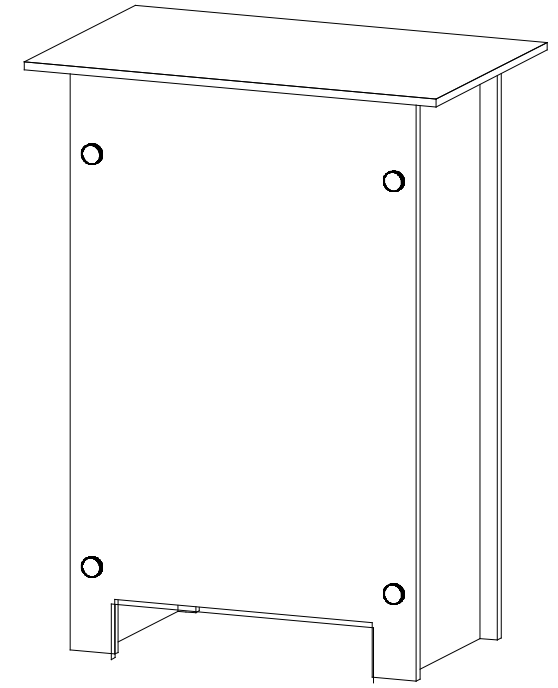

When assembled

